

### FFA Ag Mechanics State Finals 2024 ARC Welding Skills

Procedure:

You will be issued (4) pieces of material: (1) piece of 1-1/2" black pipe and (3) pieces of 3/8" x 4" x 4" hot rolled flat. Assemble the material according to the specifications below, using the welding rod of your choice. You are allowed to tack-weld the assembly together in any position, but the actual welding must be done as specified below. Any contestants caught welding in an incorrect position will lose the points for that particular weld. When you are finished, quench your project, make sure your contestant number is written on your project and the backside of this sheet, and submit your project to the judges.

B

B

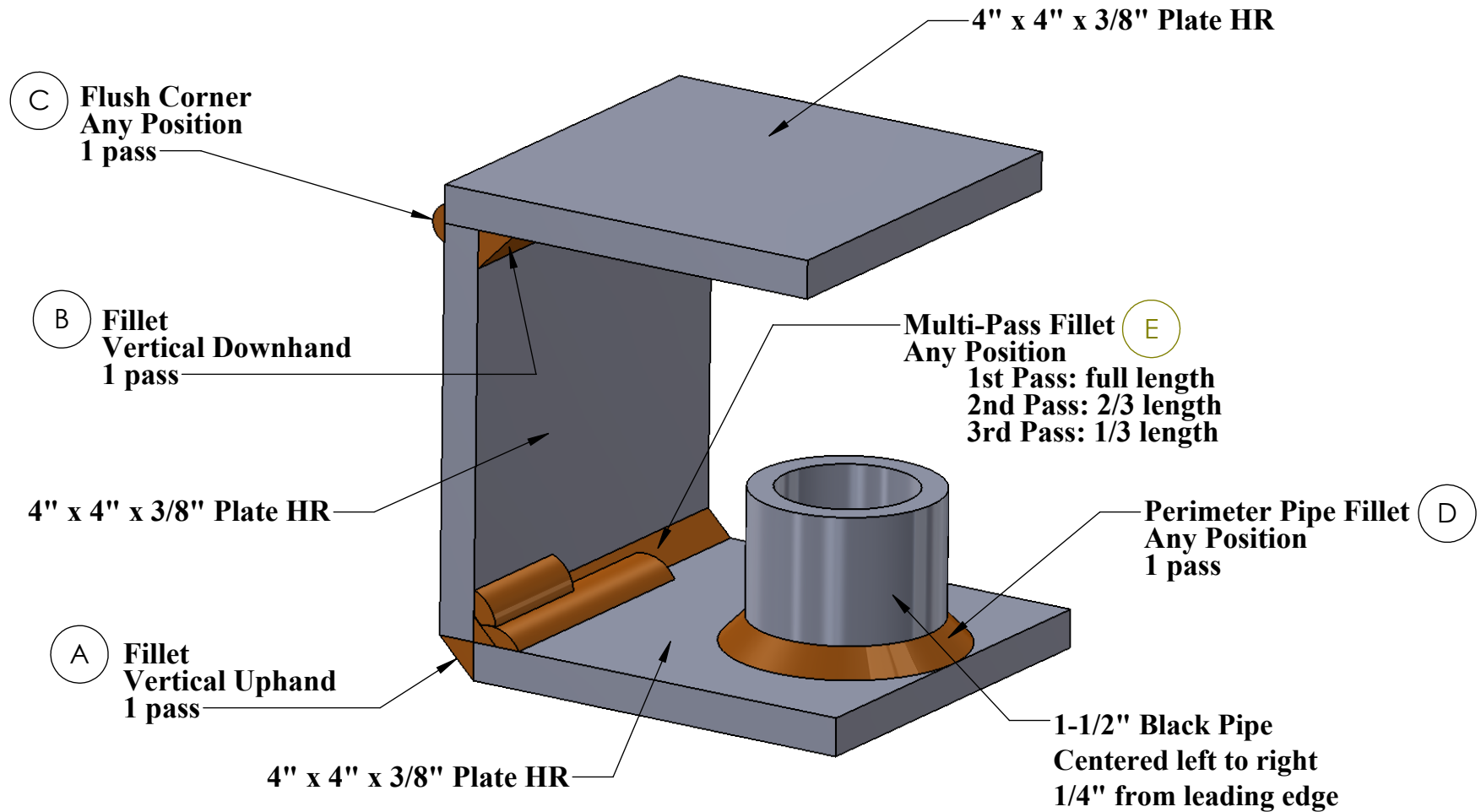

A

A

<b>Contestant No.</b>
<b>Name</b>

## FFA Ag. Mechanics State Finals 2024

### Arc Welding Skills

#### Score Sheet

**Score**

	Points Possible	Points Earned
<b>Safety and work habits</b>	<b>10</b>	<input style="width: 100%; height: 20px;" type="text"/>
<b>Correct assembly</b>	<b>10</b>	<input style="width: 100%; height: 20px;" type="text"/>
<b>A: Single Fillet, Vertical Uphand 1 pass</b>	<b>20</b>	<input style="width: 100%; height: 20px;" type="text"/>
<b>B: Single Fillet, Vertical Downhand, 1 pass</b>	<b>10</b>	<input style="width: 100%; height: 20px;" type="text"/>
<b>C: Flush Corner, Any Position, 1 pass</b>	<b>10</b>	<input style="width: 100%; height: 20px;" type="text"/>
<b>D: Perimeter Pipe Weld, Fillet, Any Position</b>	<b>20</b>	<input style="width: 100%; height: 20px;" type="text"/>
<b>E: Staggered 3 Pass Fillet, Horizontal Position</b>	<b>20</b>	<input style="width: 100%; height: 20px;" type="text"/>
<b>Totals</b>	<b>100</b>	<input style="width: 100%; height: 20px;" type="text"/>