

2

1

FFA Ag. Mechanics State Finals 2025 Arc Welding Skills

Procedure:

You will be issued 3 pieces of material: (2) pieces of 3/8" x 4" x 5" HR flat and (1) piece of 1-1/2" sch 40 black pipe. Assemble the material according to the specifications below, using the welding rod of your choice. You are allowed to tack-weld the assembly together in any position, but the welding must be done as specified below. Any contestants caught welding in an incorrect position will lose the points for that particular weld. When you are finished, quench your project, make sure your name is clearly written on your project and the backside of this sheet, and submit your project to the judges.

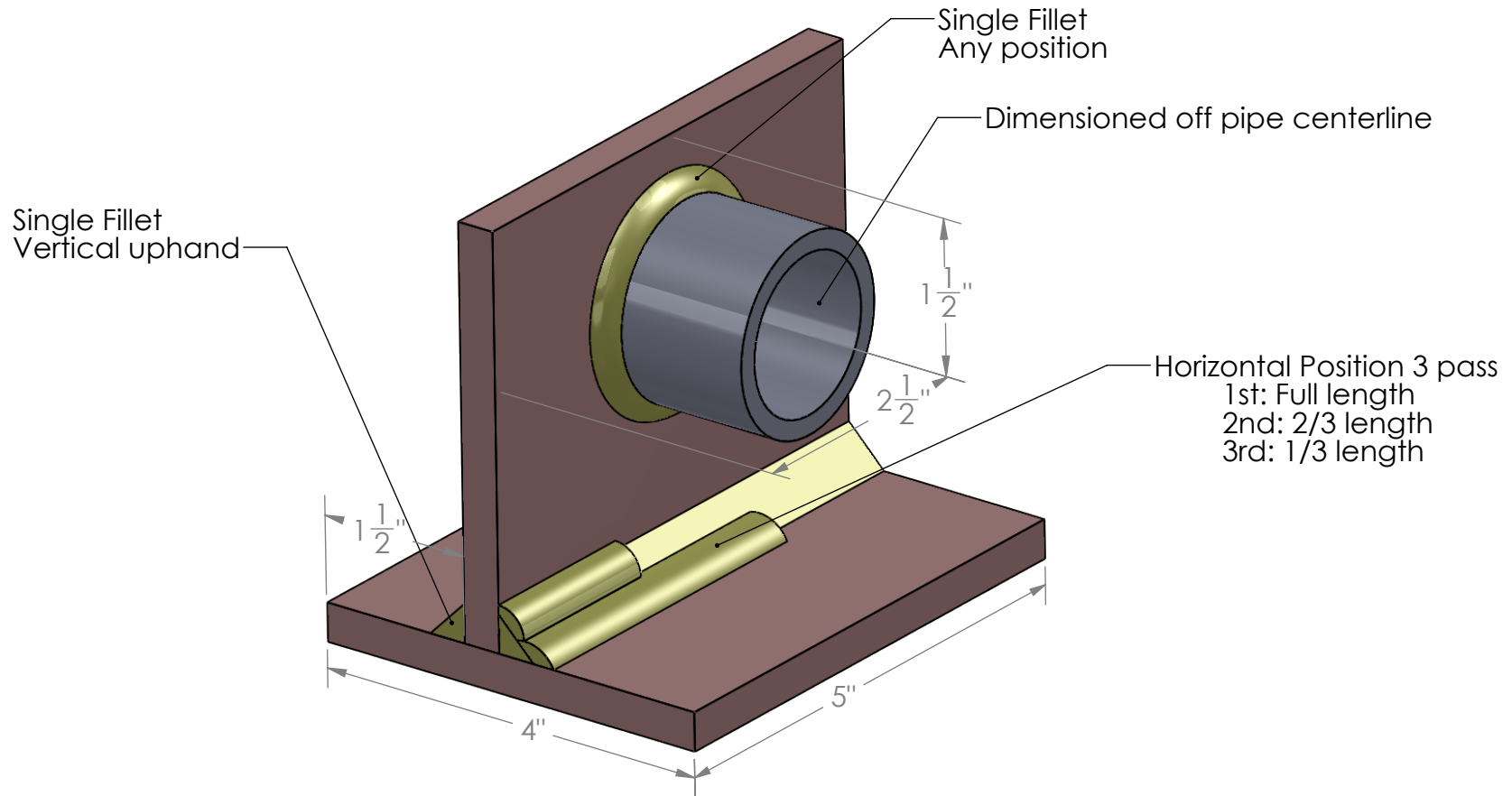

B

B

A

A

2

1

Contestant No.
Name

**FFA Ag. Mechanics State Finals 2025
Shielded Metal
Arc Welding Skills**

Score

Score Sheet

Points Possible Points Earned

Correct assembly

Pipe Position

Vertically

5

Horizontally

5

Plate position

10

Squareness

10

A: Single Fillet, Vertical uphand

25

B: Multi-pass Horizontal Fillet

25

C: Single Fillet around pipe

20

Total

100